

# Registri in števci

Digitalna vezja

Miha Moškon

[miha.moskon@fri.uni-lj.si](mailto:miha.moskon@fri.uni-lj.si)

<https://fri.uni-lj.si/en/about-faculty/employees/miha-moskon>

# Shranjevalni register

Shranjevanje več bitov

Paralelno pisanje, paralelno branje (PIPO)

Primer izvedbe 4-bitnega shranjevalnega registra z D pomnilnimi celicami

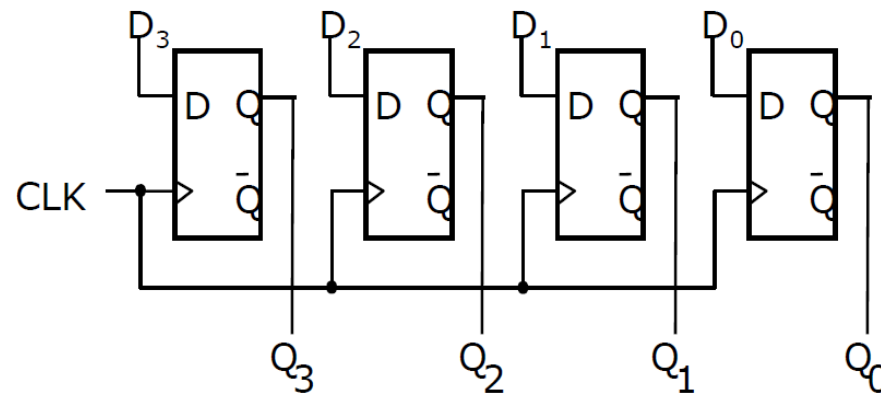

Dodatek: logika za omogočanje pisanja (*write enable*)

# Pomikalni registri

Serijsko pisanje, serijsko branje (SISO)

Paralelno pisanje, serijsko branje (PISO)

Serijsko pisanje, paralelno branje (SIPO)

Primer izvedbe 4-bitnega SISO registra z D pomnilnimi celicami

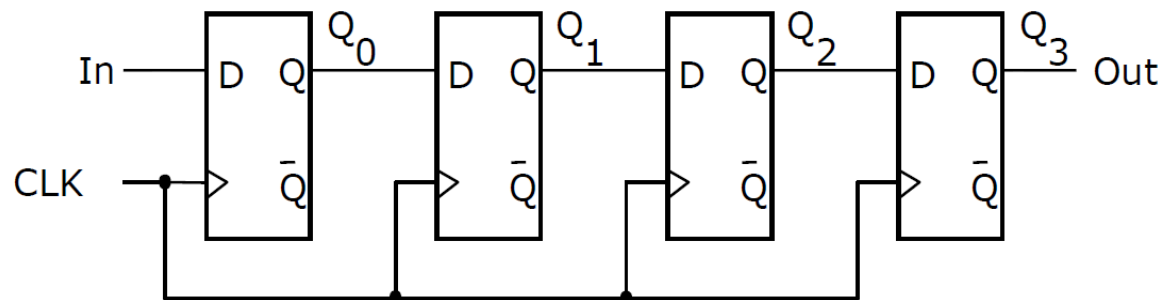

# Univerzalni register

Primer realizacije z MUX 4/1

S0,S1: določata način delovanja

S0=1 S1=1: nalaganje (a,b,c,d) →  
(Qa, Qb, Qc, Qd)

S0=1 S1=0: pomikanje levo (v smeri  
Qd → Qa); Qd ← SL

S0=0 S1=1: pomikanje desno (v  
smeri Qa → Qd); Qa ← SR

S0=0 S1=0: ohranjanje vsebine  
(hold)

Čip 74194

PRIKLJUČEK	FUNKCIJA
CLEAR	Asinhrono brisanje (negativna logika)
SR	Zaporedni vhod (ob pomikanju desno)
A,B,C,D	Vzporedni vhodi
SL	Zaporedni vhod (ob pomikanju levo)
S0, S1	vhoda za določanje načina delovanja
CLOCK	Clock Input (negative edge triggered)
QA,QB,QC,QD	Vzporedni izhodi

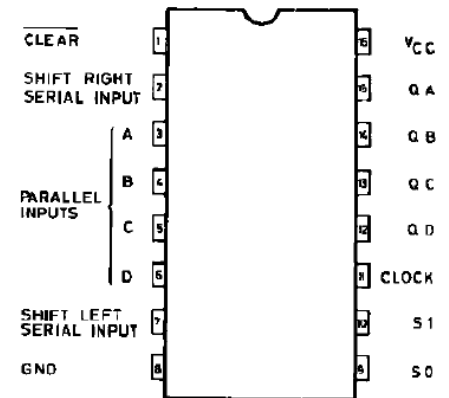

# Univerzalni register

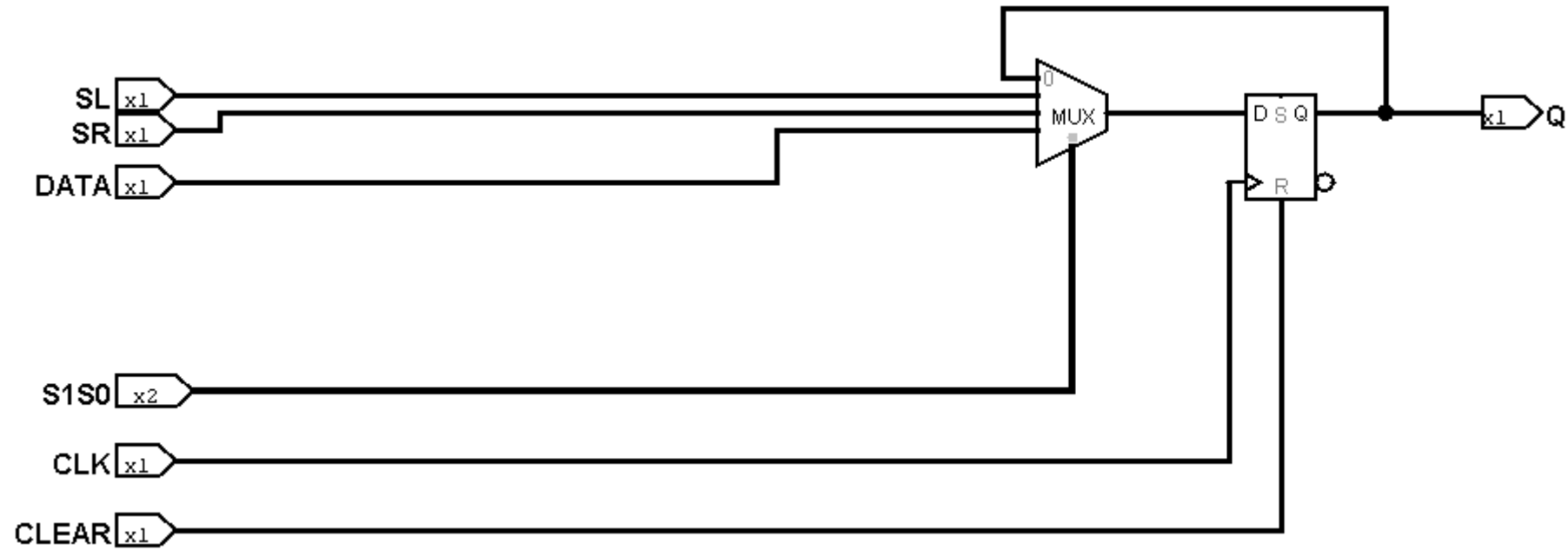
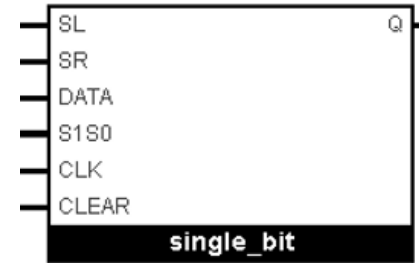

# Univerzalni register

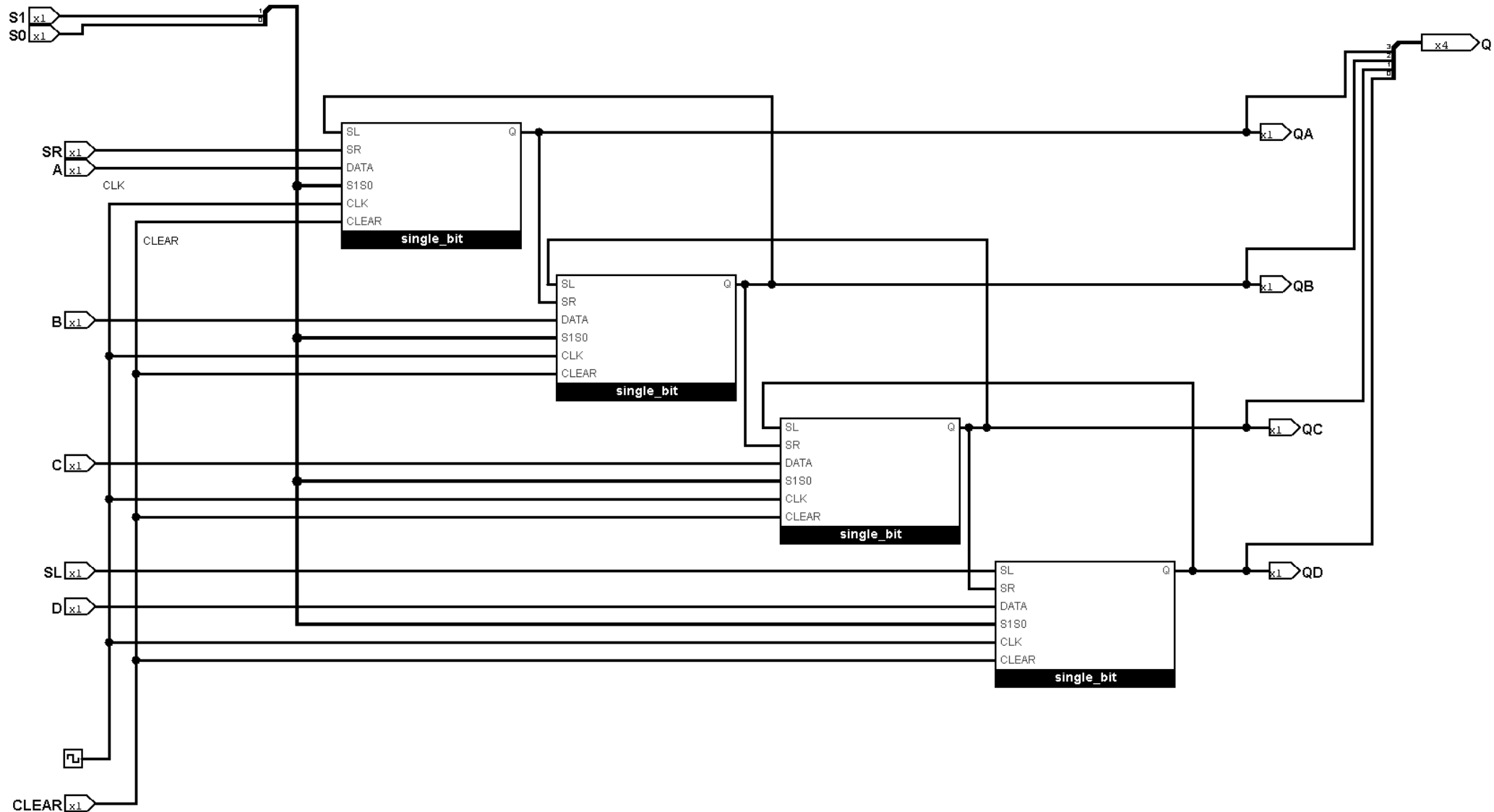

# Uporaba 74194: krmilnik unipolarnega koračnega motorja

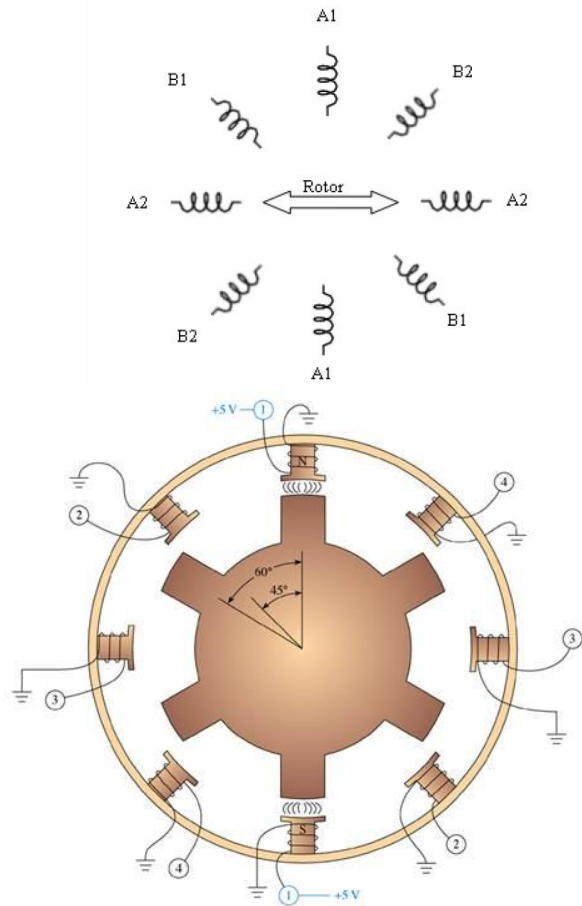

NAČIN		trenutno				naslednje			
S1	S0	Q <sub>a</sub>	Q <sub>b</sub>	Q <sub>c</sub>	Q <sub>d</sub>	Q <sub>a</sub>	Q <sub>b</sub>	Q <sub>c</sub>	Q <sub>d</sub>
0	0								
0	0								
0	0								
0	0								
0	1	1	0	0	0	0	1	0	0
0	1	0	1	0	0	0	0	1	0
0	1	0	0	1	0	0	0	0	1
0	1	0	0	0	1	1	0	0	0
1	0	1	0	0	0	0	0	0	1
1	0	0	1	0	0	1	0	0	0
1	0	0	0	1	0	0	1	0	0
1	0	0	0	0	1	0	0	1	0
1	1								
1	1								
1	1								
1	1								

load

hold

# Uporaba 74194: krmilnik unipolarnega koračnega motorja

Krmiljenje preko signalov CLK (hitrost), S1 in S0 (način delovanja).

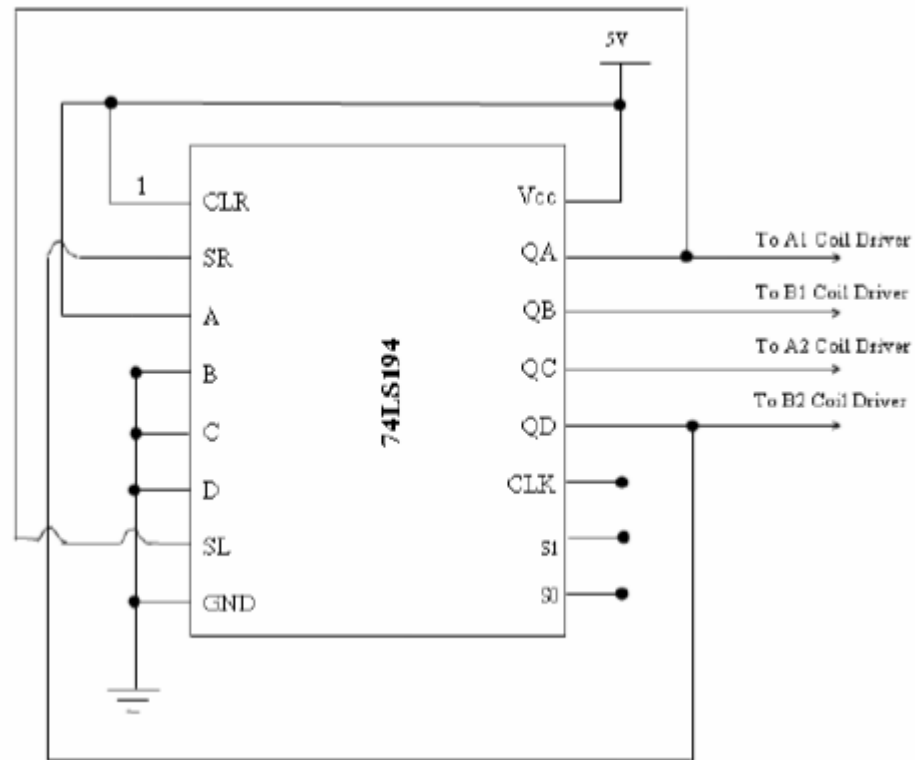



# Uporaba 74194: krmilnik unipolarnega koračnega motorja

- Problem: moč registrskih izhodov je premajhna za neposredno krmiljenje motorja.

- Uporaba NPN tranzistorjev

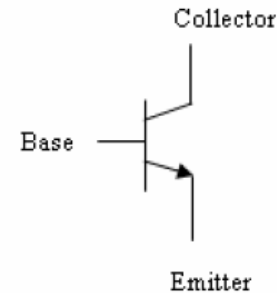

- Pri toku od baze k emiterju bo tranzistor odprt: velik tok od kolektorja k emiterju.

- Diode ščitijo tranzistor pred negativnim tokom, ki ga lahko ustvari motor.

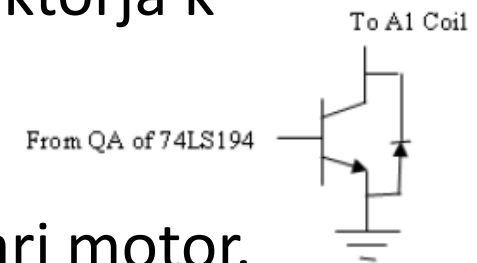

# Uporaba 74194: krmilnik unipolarnega koračnega motorja

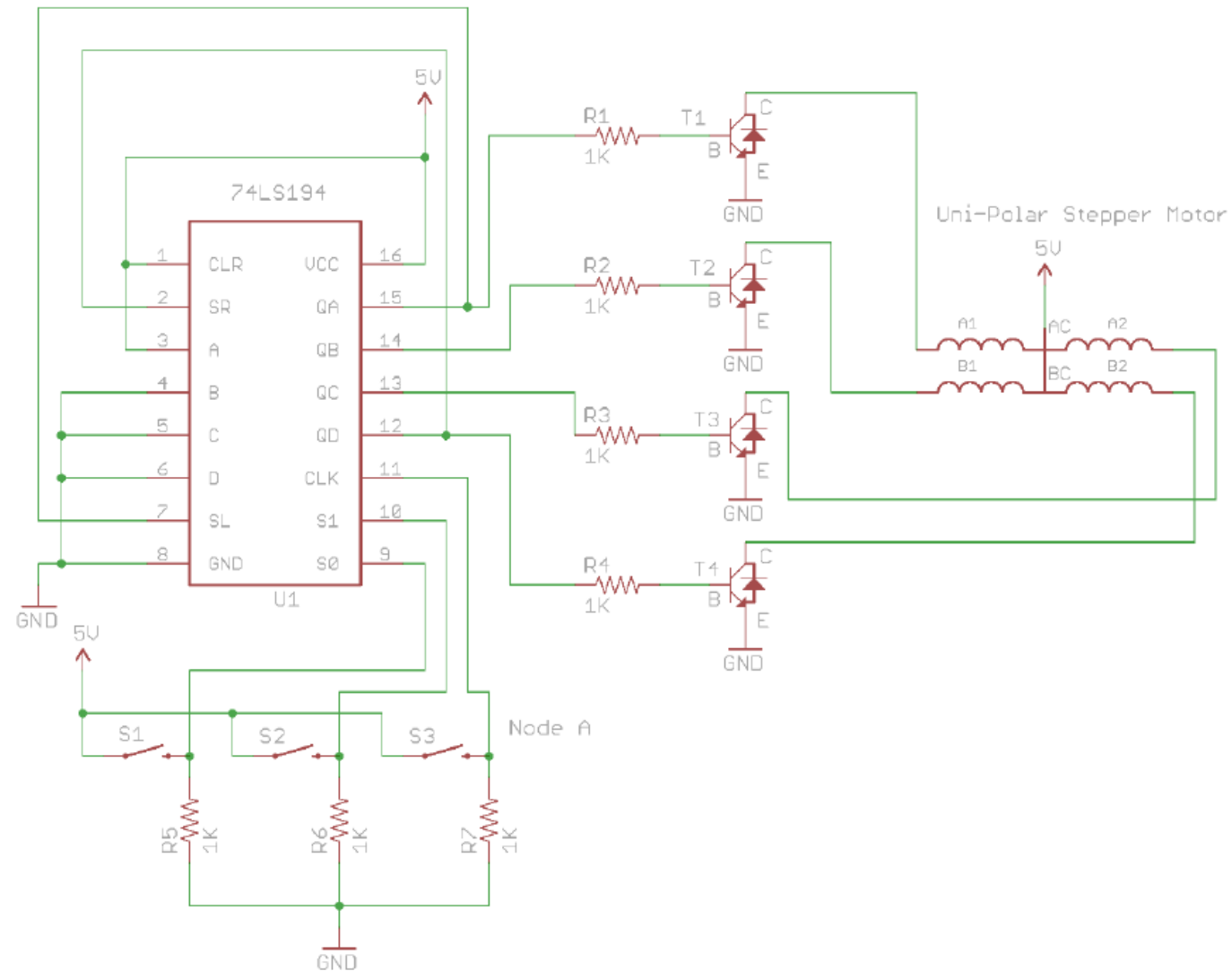

# Uporaba 74194: krmilnik unipolarnega koračnega motorja

NAČIN		trenutno				naslednje			
S1	S0	Q <sub>a</sub>	Q <sub>b</sub>	Q <sub>c</sub>	Q <sub>d</sub>	Q <sub>a</sub>	Q <sub>b</sub>	Q <sub>c</sub>	Q <sub>d</sub>
0	0								
0	0								
0	0								
0	0								
0	1	1	0	0	0	0	1	0	0
0	1	0	1	0	0	0	0	1	0
0	1	0	0	1	0	0	0	0	1
0	1	0	0	0	1	1	0	0	0
1	0	1	0	0	0	0	0	0	1
1	0	0	1	0	0	1	0	0	0
1	0	0	0	1	0	0	1	0	0
1	0	0	0	0	1	0	0	1	0
1	1								
1	1								
1	1								
1	1								

load

hold

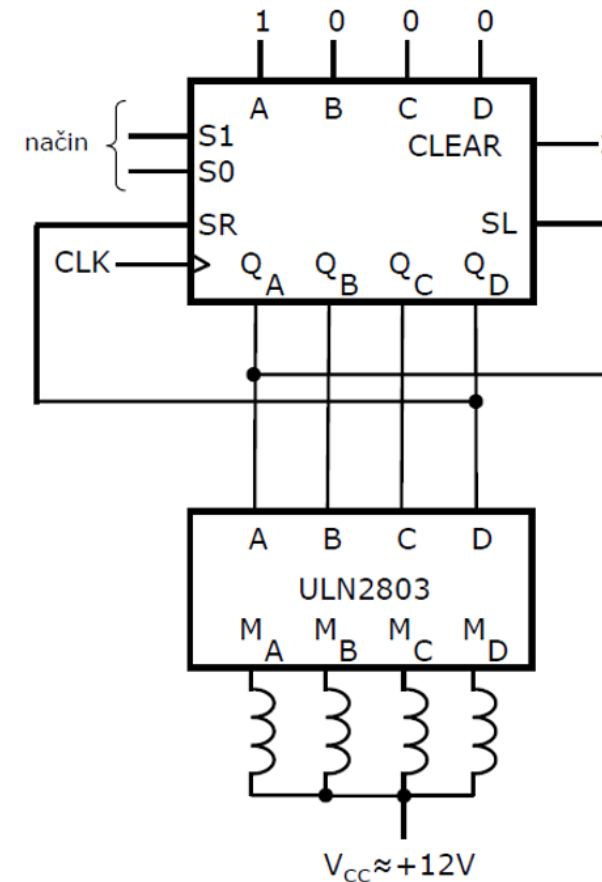

# Števec

Števec po modulu  $2^n$

$Q_2$	$Q_1$	$Q_0$	$D^1Q_2$	$D^1Q_1$	$D^1Q_0$
0	0	0	0	0	1
0	0	1	0	1	0
0	1	0	0	1	1
0	1	1	1	0	0
1	0	0	1	0	1
1	0	1	1	1	0
1	1	0	1	1	1
1	1	1	0	0	0

$$D^1q_0 = \bar{q}_0$$

$$D^1q_1 = q_1 \nabla q_0$$

$$D^1q_2 = q_2 \nabla(q_1 q_0)$$

$$D^1q_n = q_n \nabla(q_{n-1} q_{n-2} \cdots q_0)$$

# Števec 74163

## 4-bitni sinhroni števec z vzporednim vpisom

- $\overline{\text{CLR}}=0$ : izbriše vsebino števca
- $\overline{\text{LOAD}}=0$ : naloži stanje(D, C, B, A  $\rightarrow$   $Q_D, Q_C, Q_B, Q_A$ )
- ENP in ENT =1: štetje
- RCO postane 1 pri prehodu iz stanja 1111 v 0000

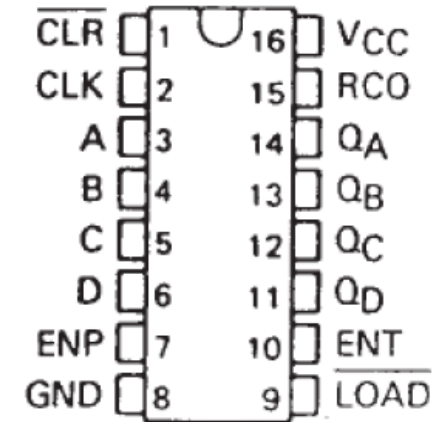

Ripple Carry Output: omogoča gradnjo večbitnih števcov s sekvenčno vezavo (brez dodatne logike)  $\rightarrow$  vežemo na ENP ali ENT.

# Števec

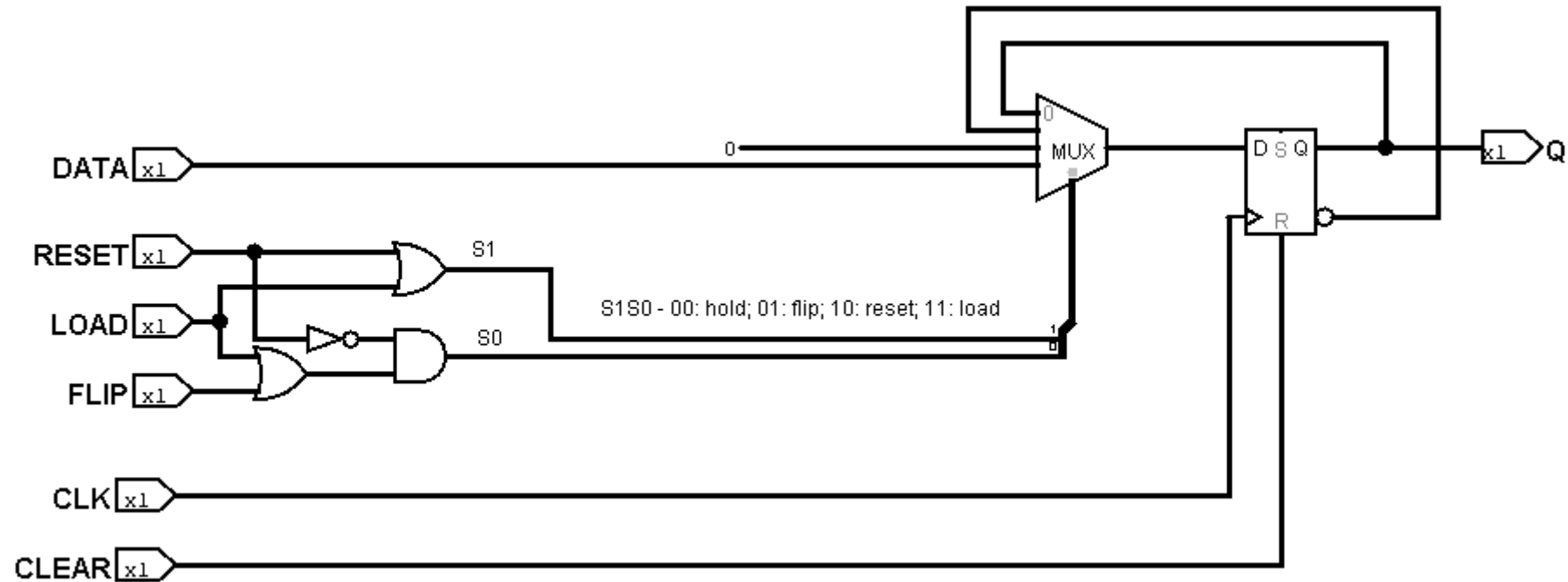
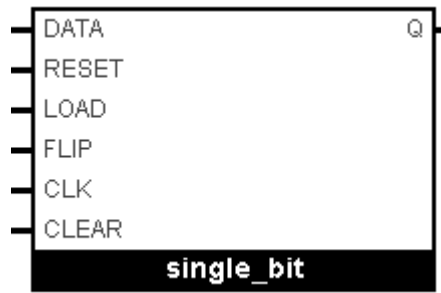

# Števec

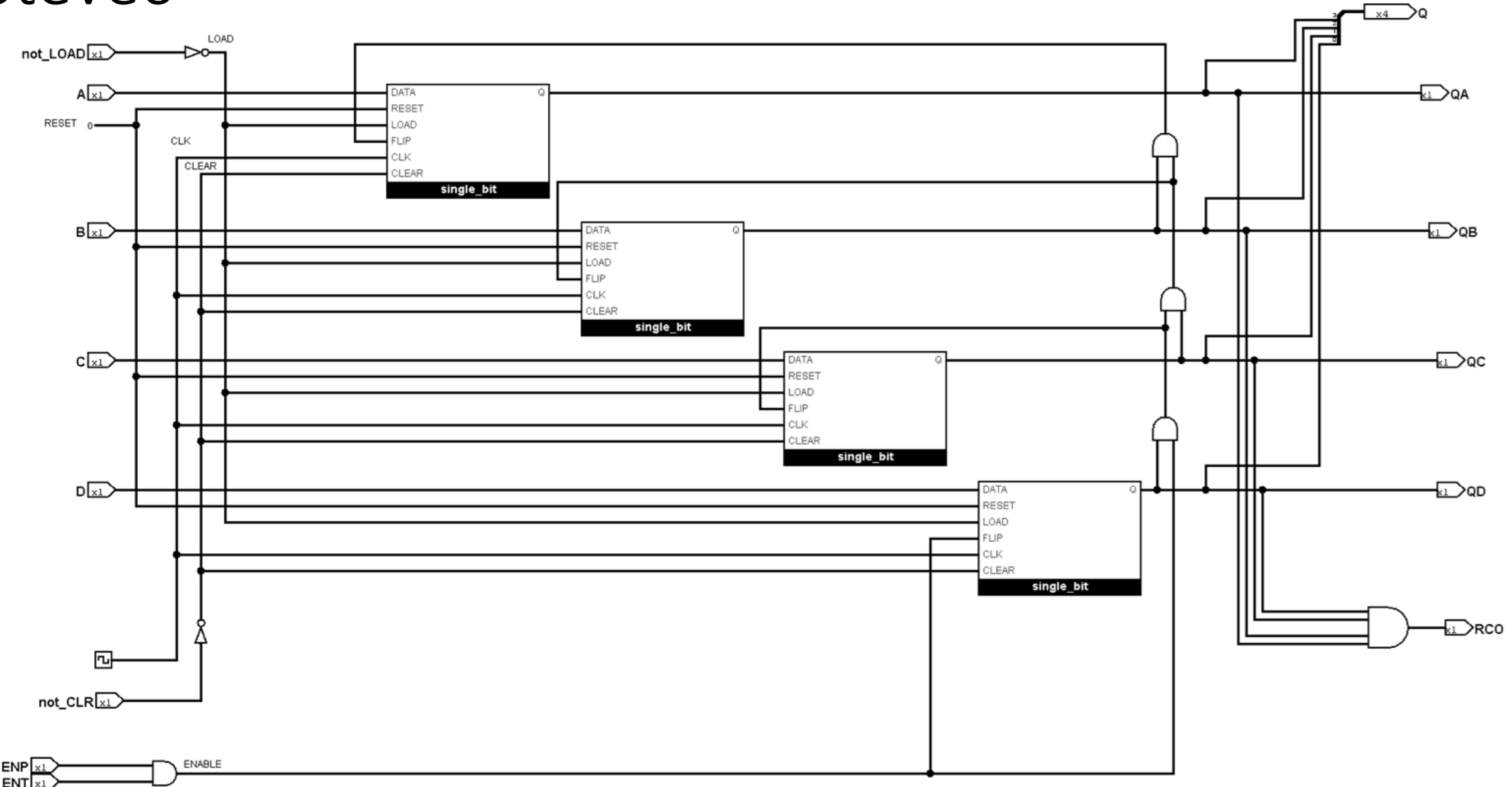

# Števec 74163 – sekvenčna vezava

Ker imamo dva Enable vhoda, ne potrebujemo dodatne logike

