

01

Uvod, tranzistor, izdelava  
tiskanega vezja

*Introduction, transistor,  
integrated circuit fabrication*

Digitalno načrtovanje

*Digital design*

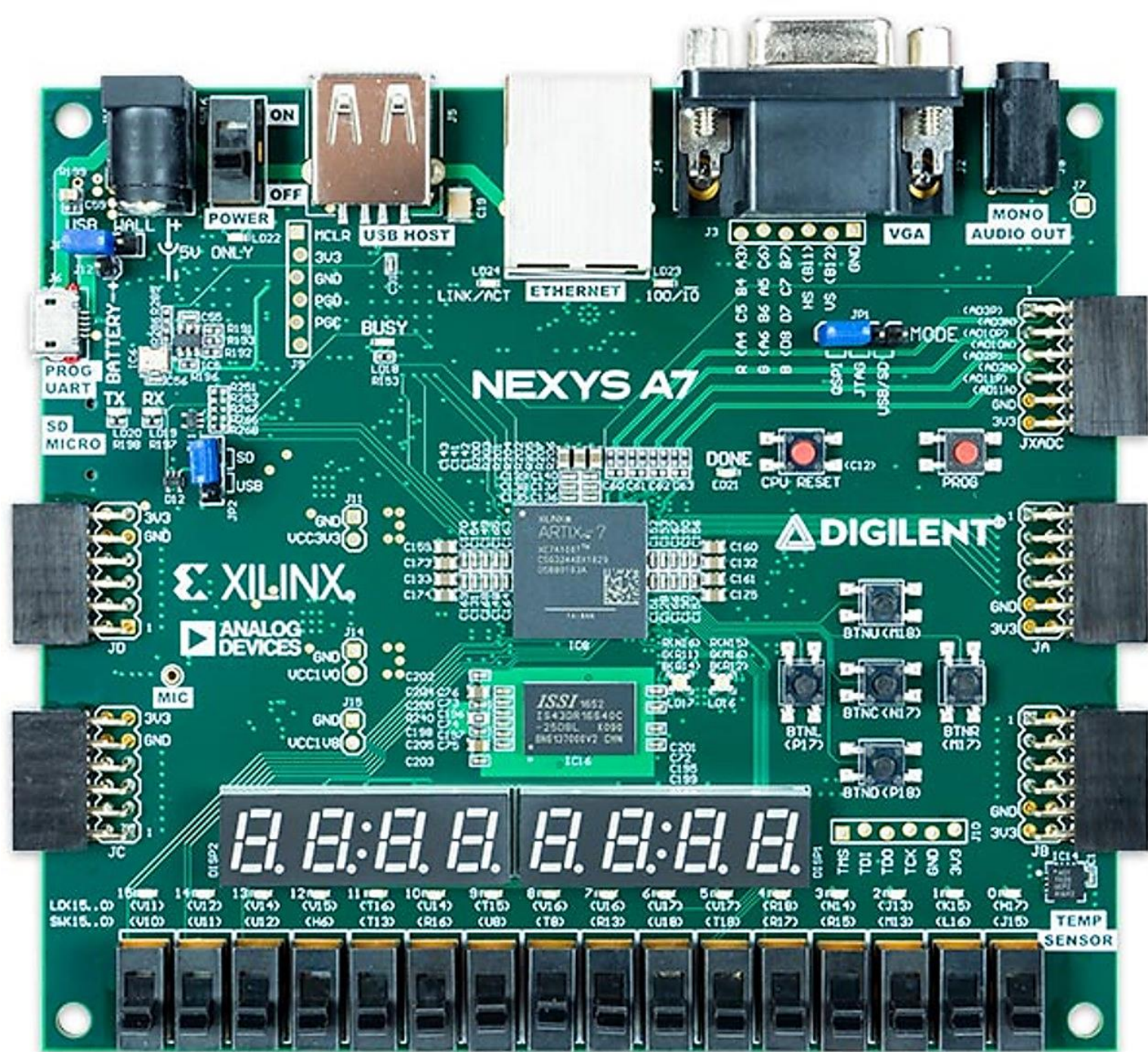

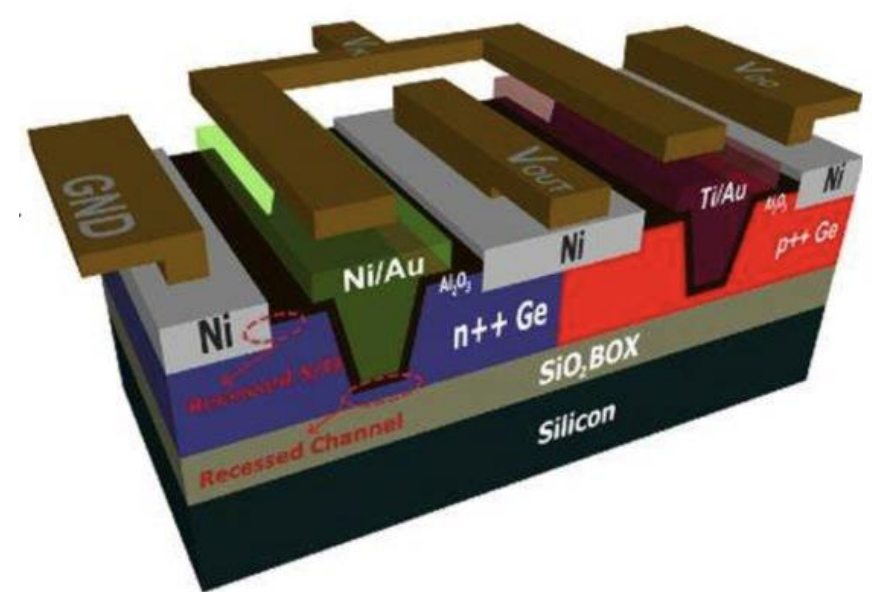
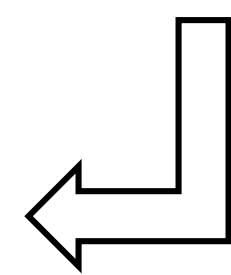
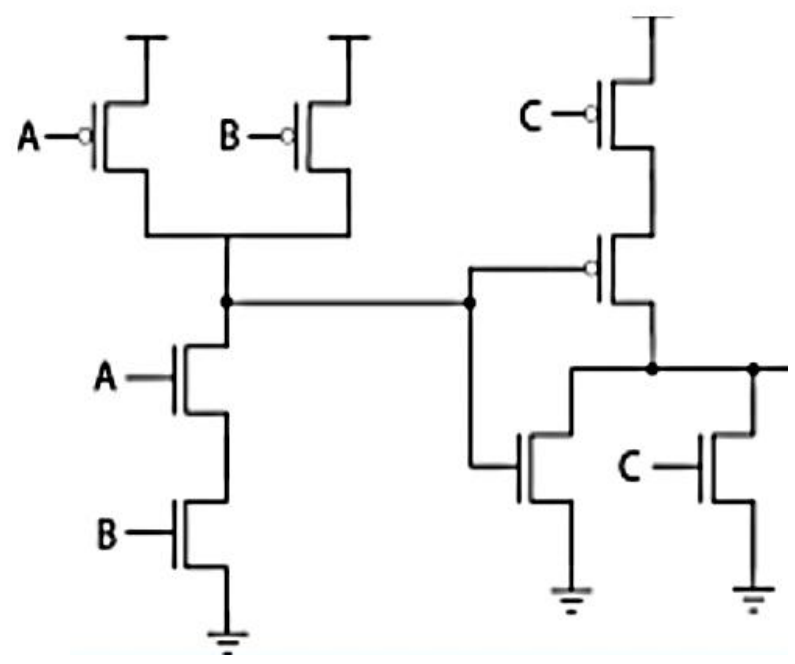
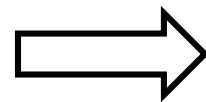
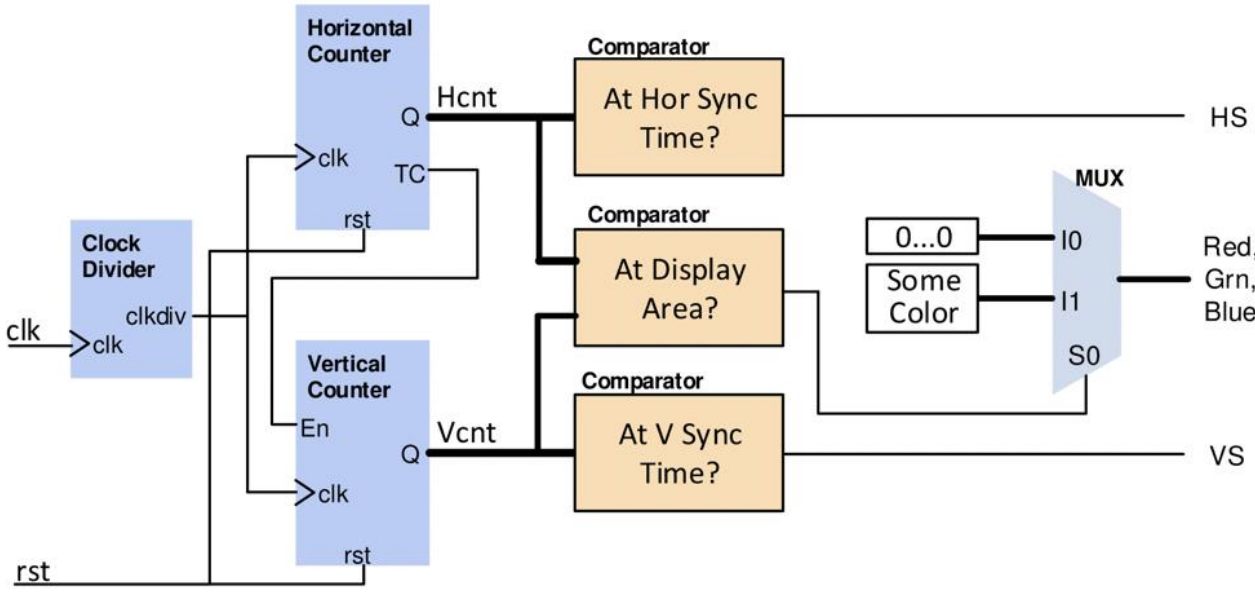

Group	1	2	3	4	5	6	7	8	9	10	11	12	13	14	15	16	17	18	
Period 1	1 H																		2 He
Period 2	3 Li	4 Be											5 B	6 C	7 N	8 O	9 F	10 Ne	
Period 3	11 Na	12 Mg											13 Al	14 Si	15 P	16 S	17 Cl	18 Ar	
Period 4	19 K	20 Ca	21 Sc	22 Ti	23 V	24 Cr	25 Mn	26 Fe	27 Co	28 Ni	29 Cu	30 Zn	31 Ga	32 Ge	33 As	34 Se	35 Br	36 Kr	
Period 5	37 Rb	38 Sr	39 Y	40 Zr	41 Nb	42 Mo	43 Tc	44 Ru	45 Rh	46 Pd	47 Ag	48 Cd	49 In	50 Sn	51 Sb	52 Te	53 I	54 Xe	
Period 6	55 Cs	56 Ba	* 71 Lu	72 Hf	73 Ta	74 W	75 Re	76 Os	77 Ir	78 Pt	79 Au	80 Hg	81 Tl	82 Pb	83 Bi	84 Po	85 At	86 Rn	
Period 7	87 Fr	88 Ra	* * 103 Lr	104 Rf	105 Db	106 Sg	107 Bh	108 Hs	109 Mt	110 Ds	111 Rg	112 Cn	113 Nh	114 Fl	115 Mc	116 Lv	117 Ts	118 Og	
			* 57 La	58 Ce	59 Pr	60 Nd	61 Pm	62 Sm	63 Eu	64 Gd	65 Tb	66 Dy	67 Ho	68 Er	69 Tm	70 Yb			
			* * 89 Ac	90 Th	91 Pa	92 U	93 Np	94 Pu	95 Am	96 Cm	97 Bk	98 Cf	99 Es	100 Fm	101 Md	102 No			

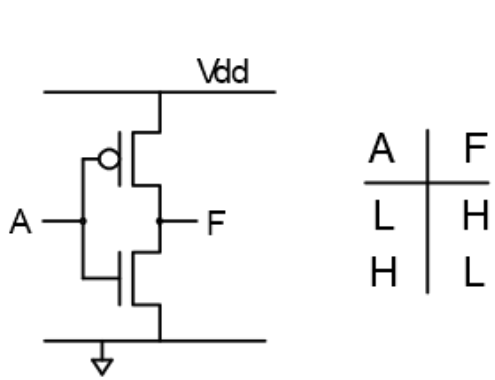

NOT

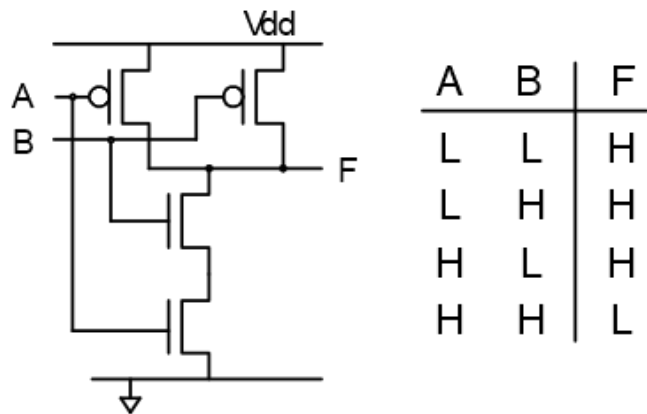

NAND

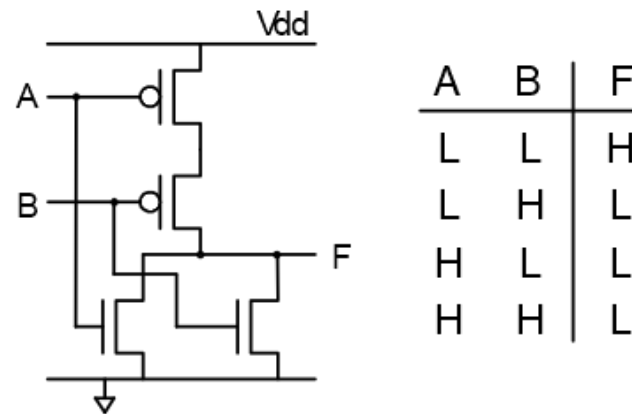

NOR

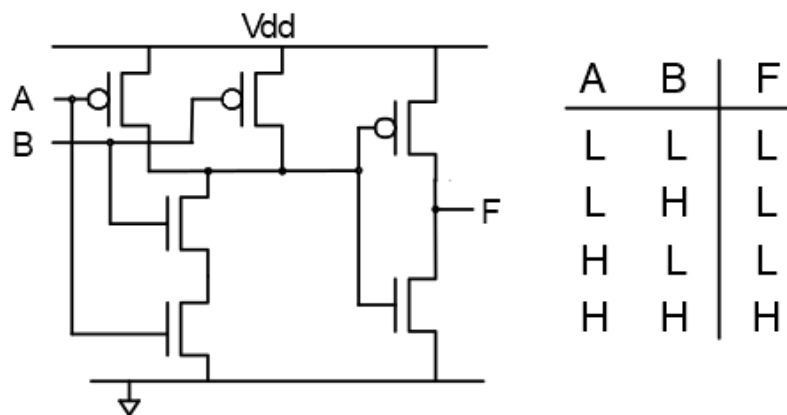

AND

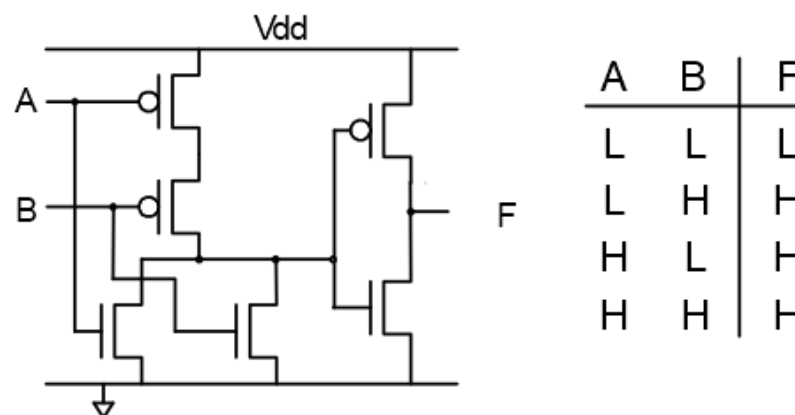

OR



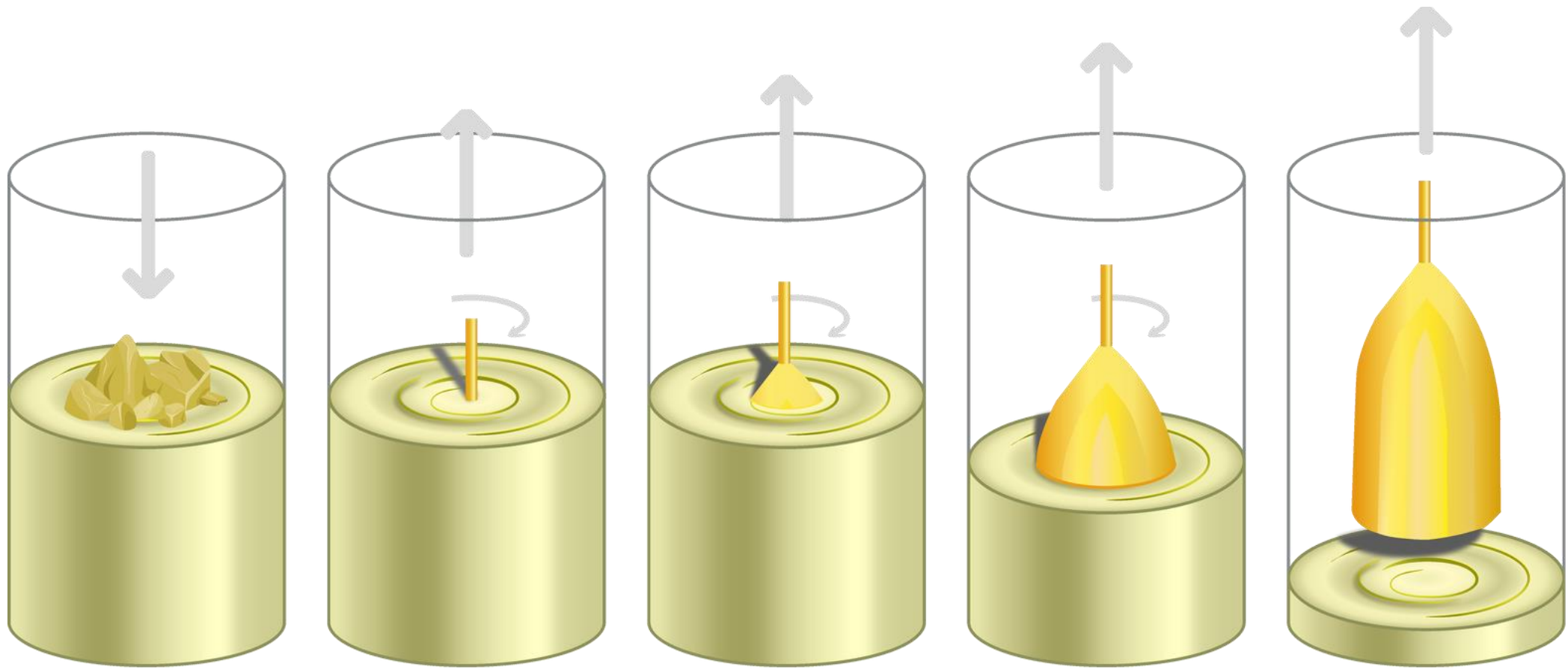

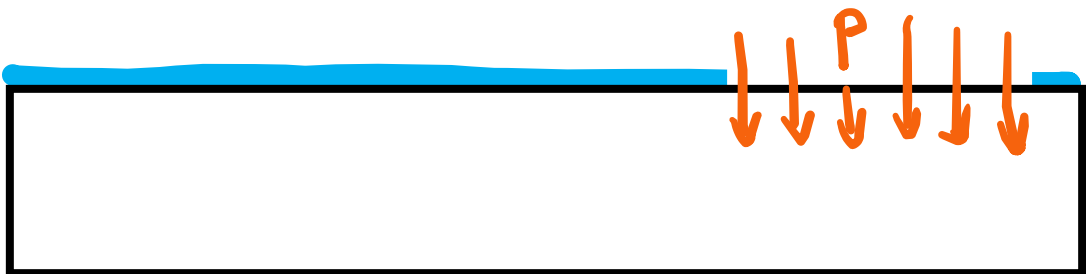
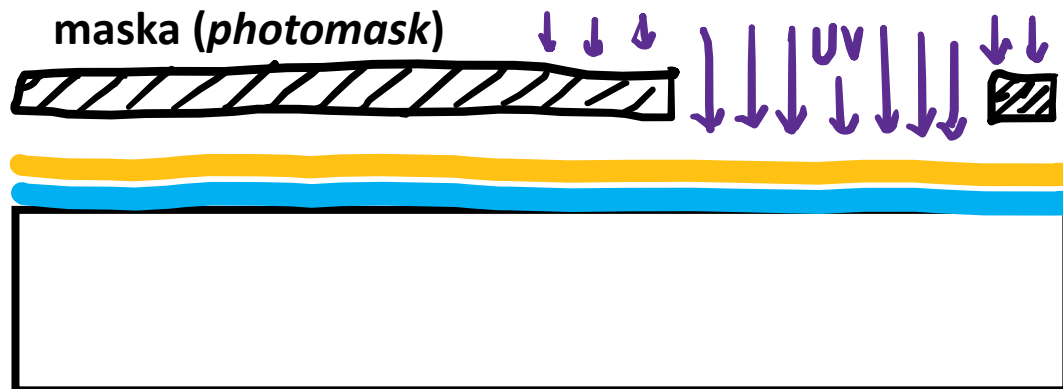
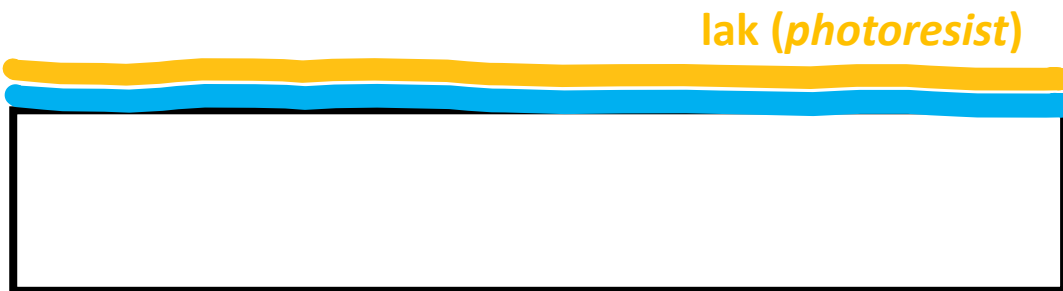
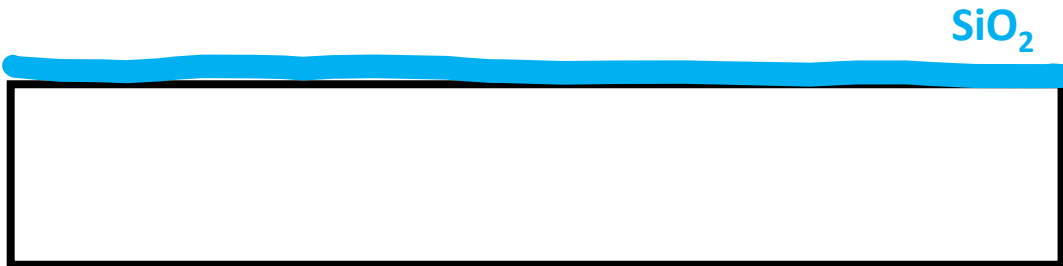
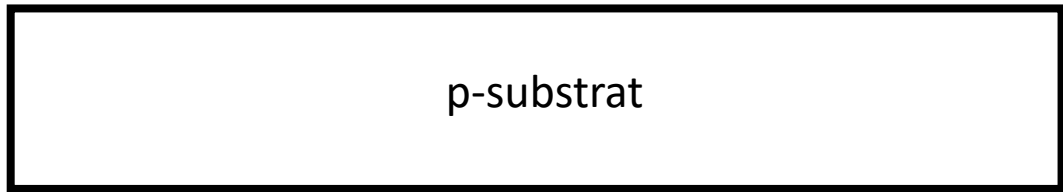



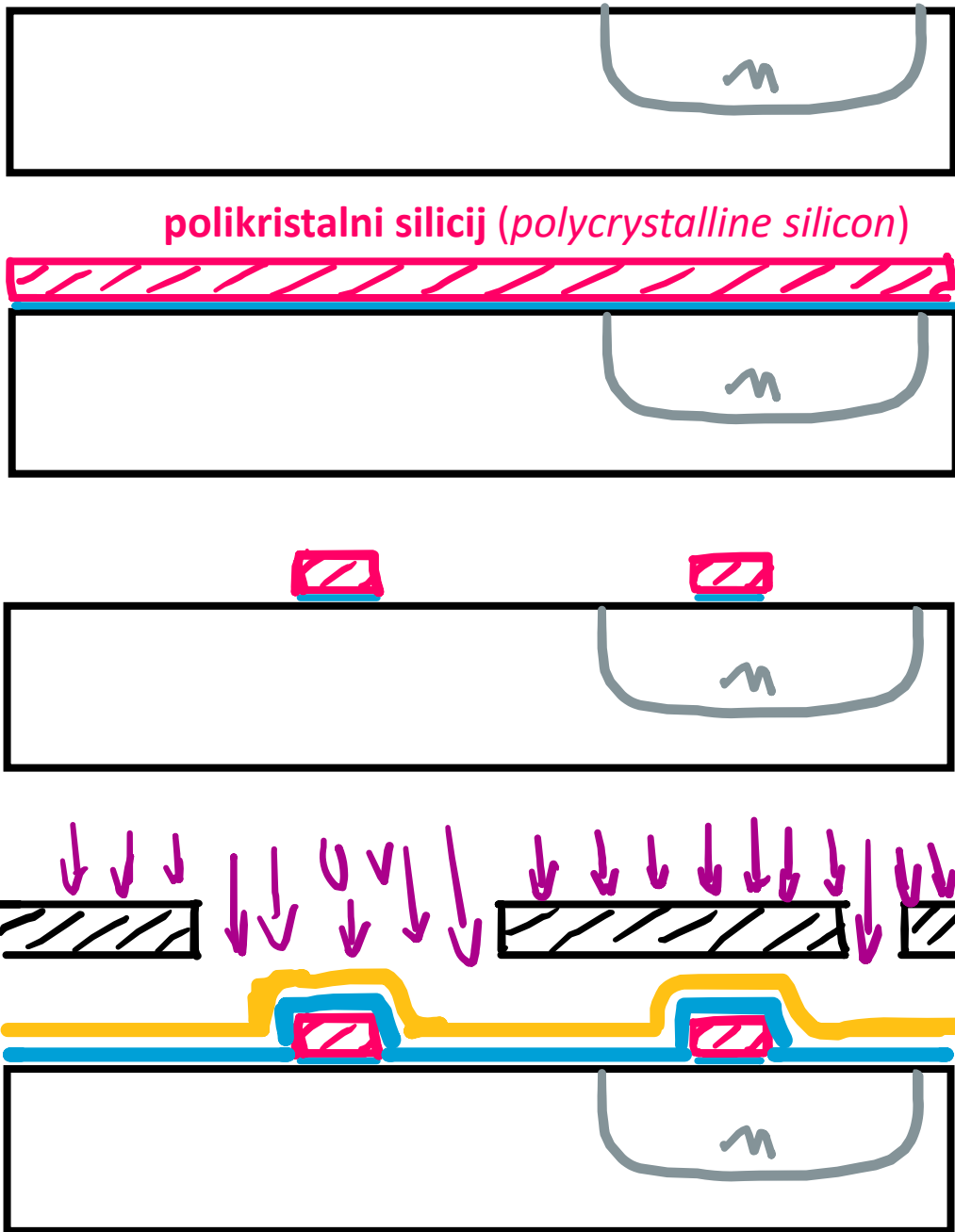

$\text{SiO}_2$   
tanka plast  
(*thin layer*)

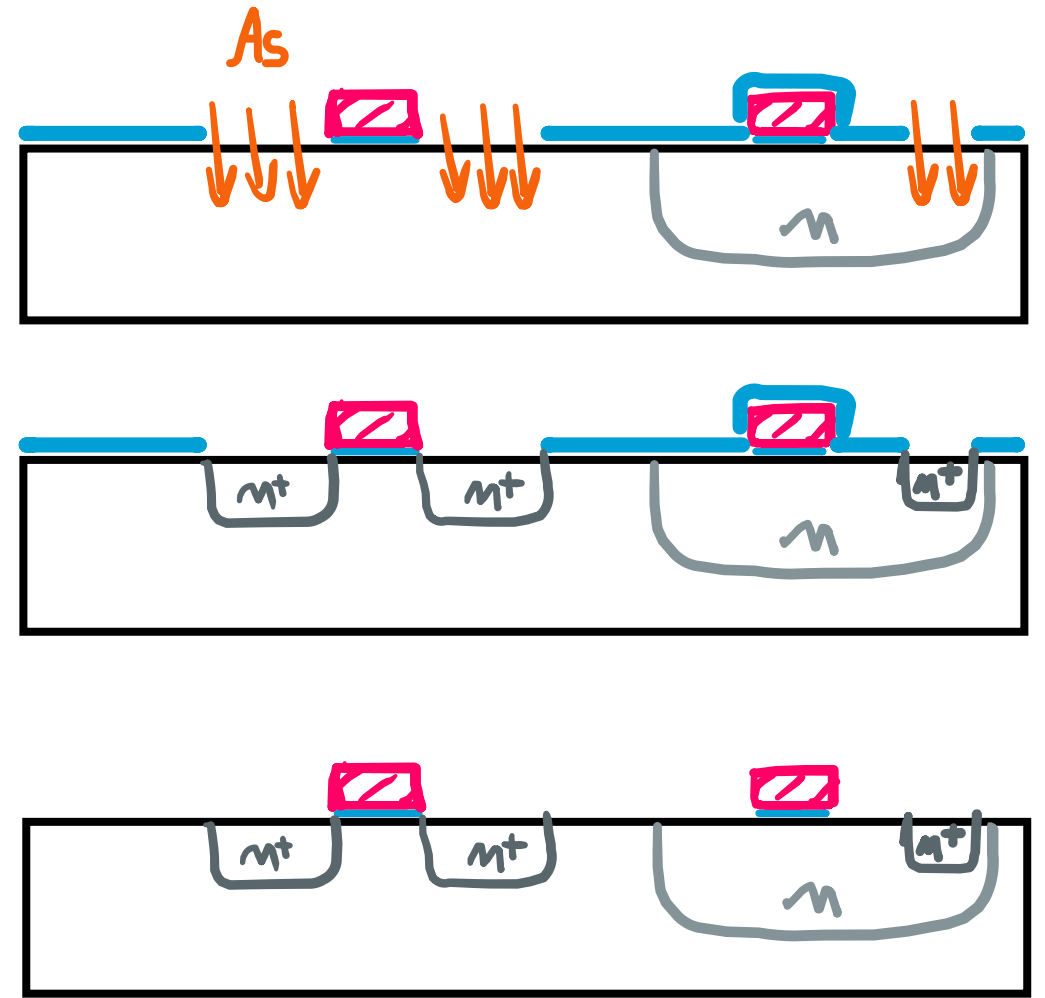

Sledi ponovna oksidacija,  
premaz z lakom,  
obsevanje ...  
in dopiranje z borom (B)

*New cycle of oxidation,  
coating with photoresist,  
developing, exposure ...  
and doping with boron (B)*

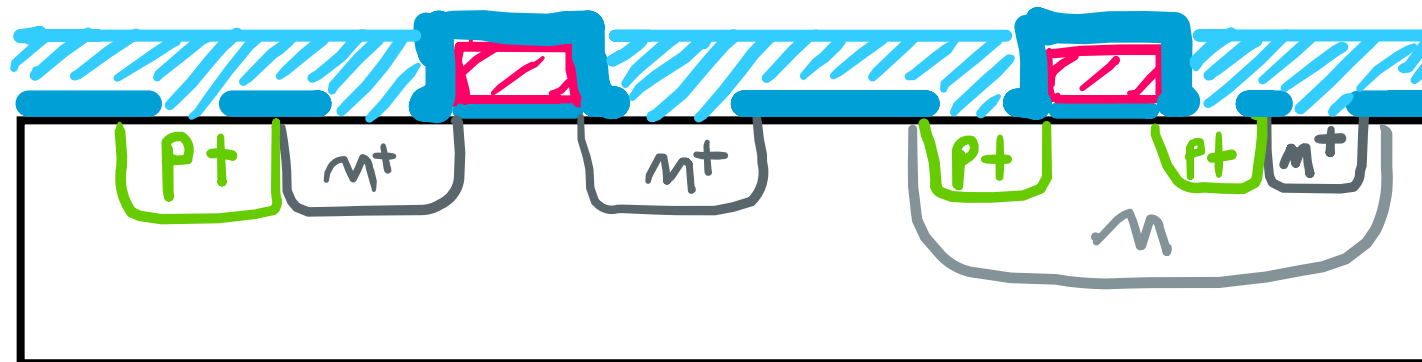
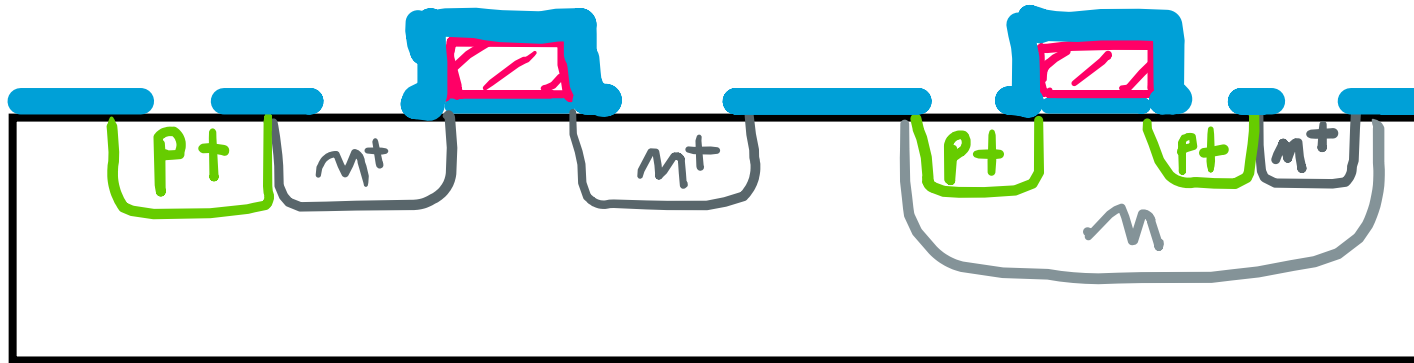
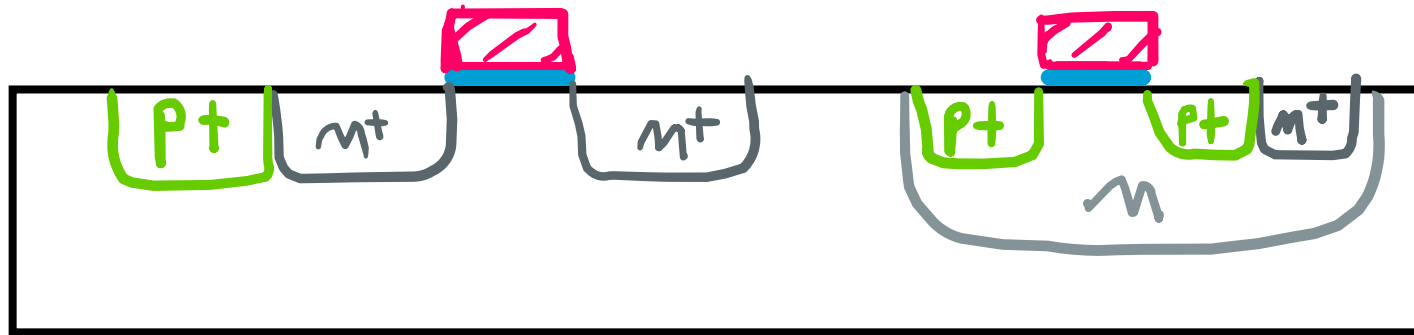

*kovina (metal)*

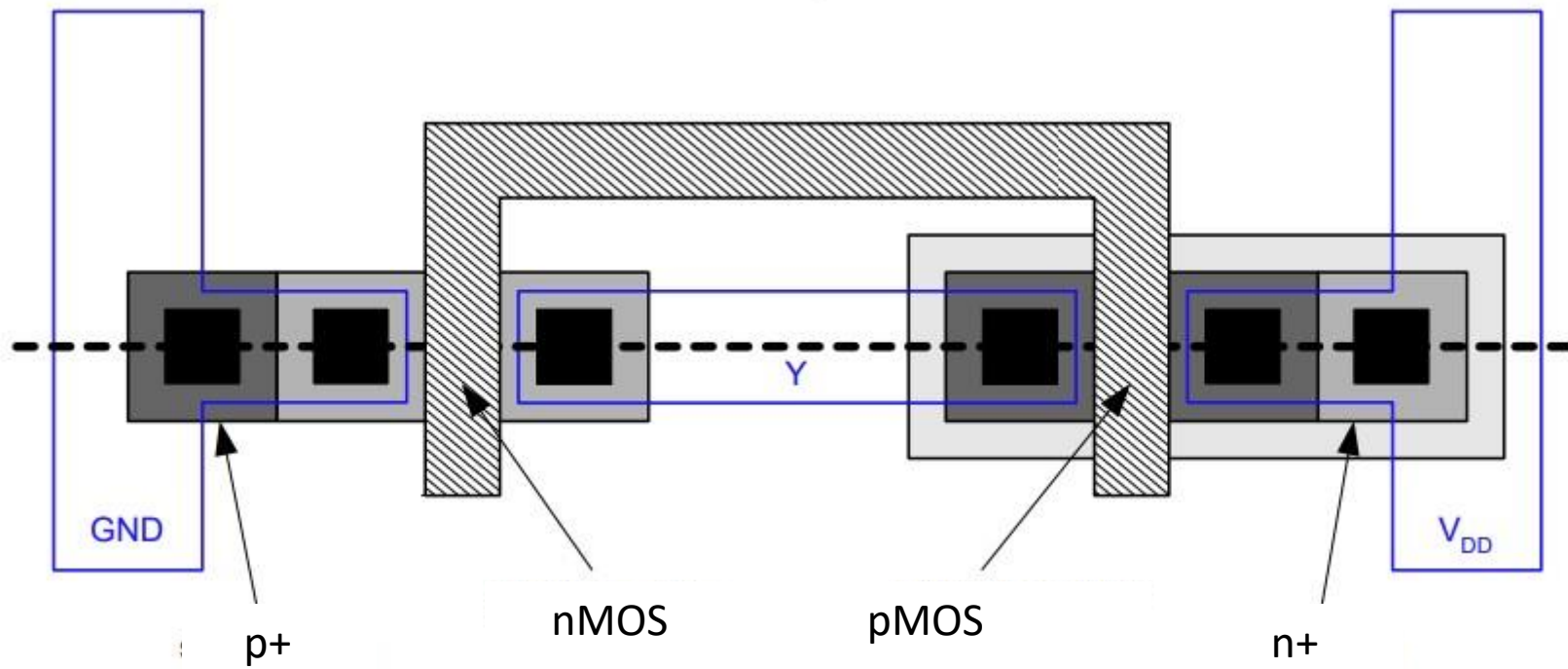

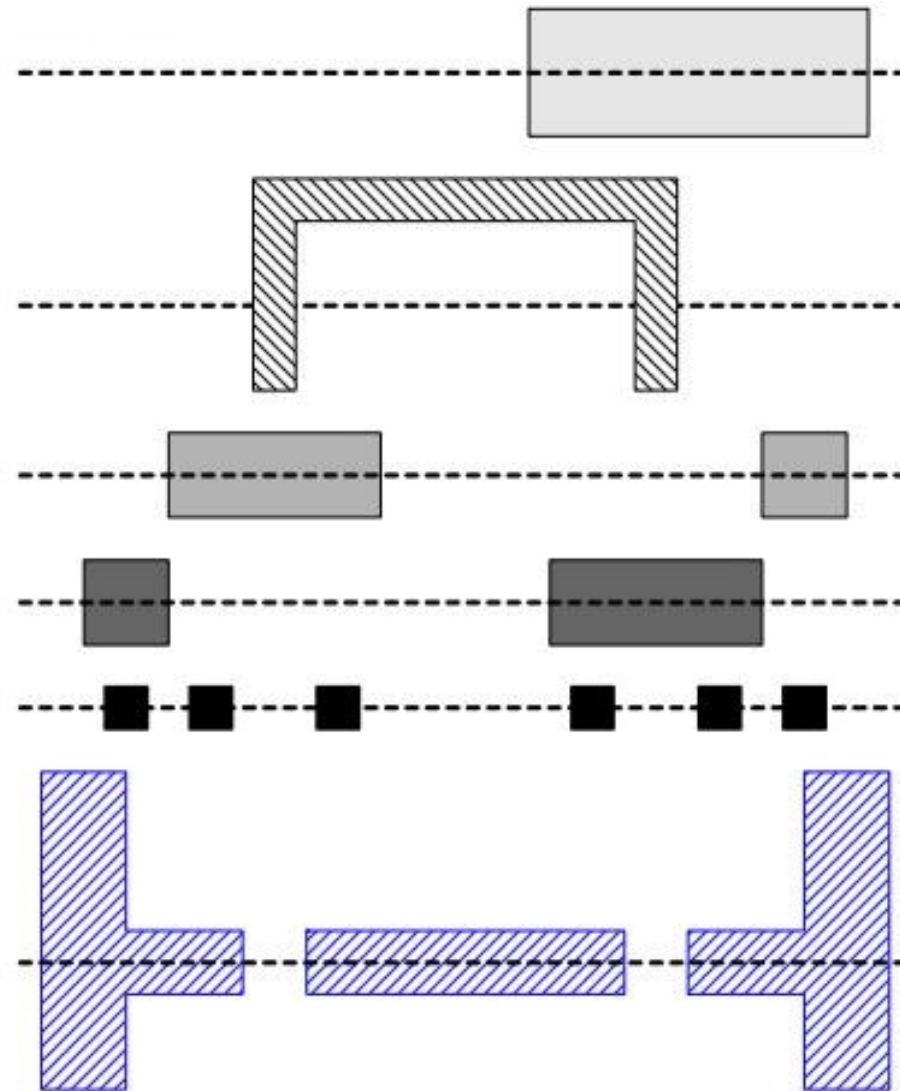

n-bazen (*n-well*)

polikristalni silicij  
(*polysilicon*)

n+ območje (*n+ diffusion*)

p+ območje (*p+ diffusion*)

priključki (*contacts*)

kovina (*metal*)

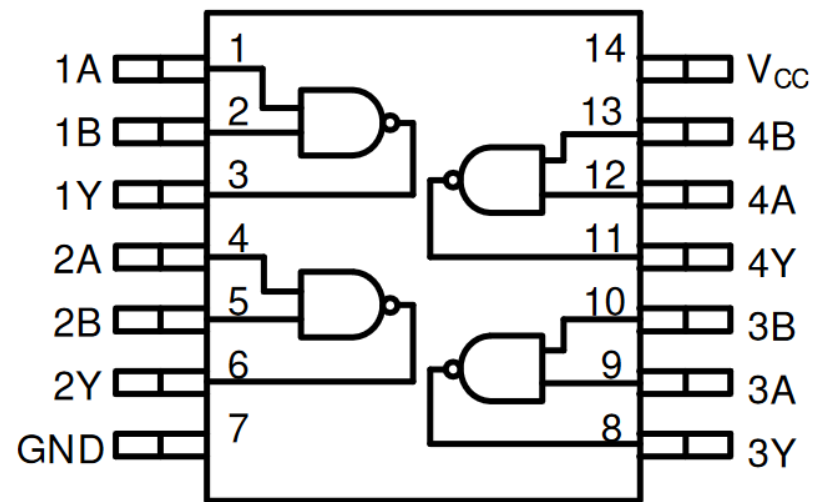
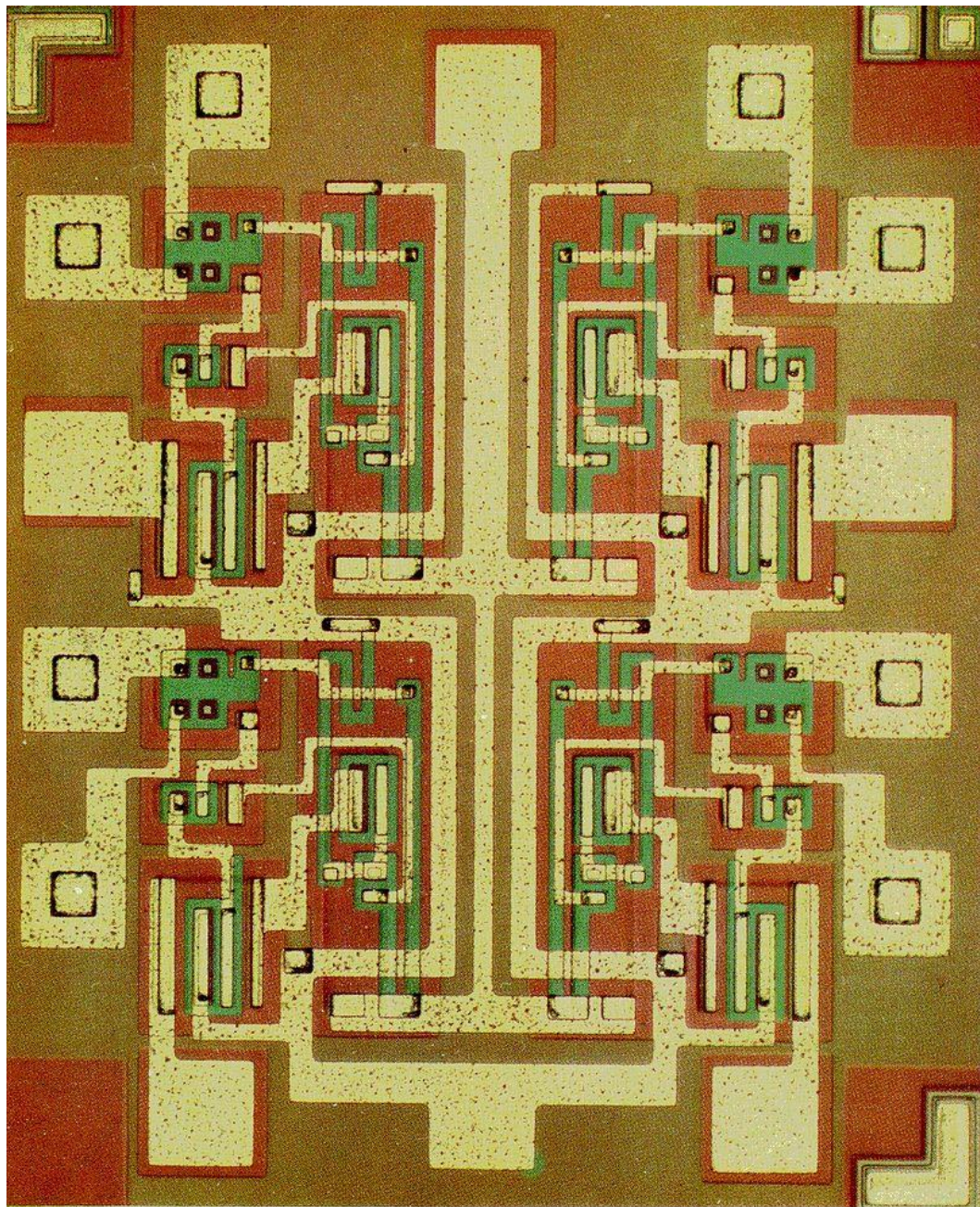

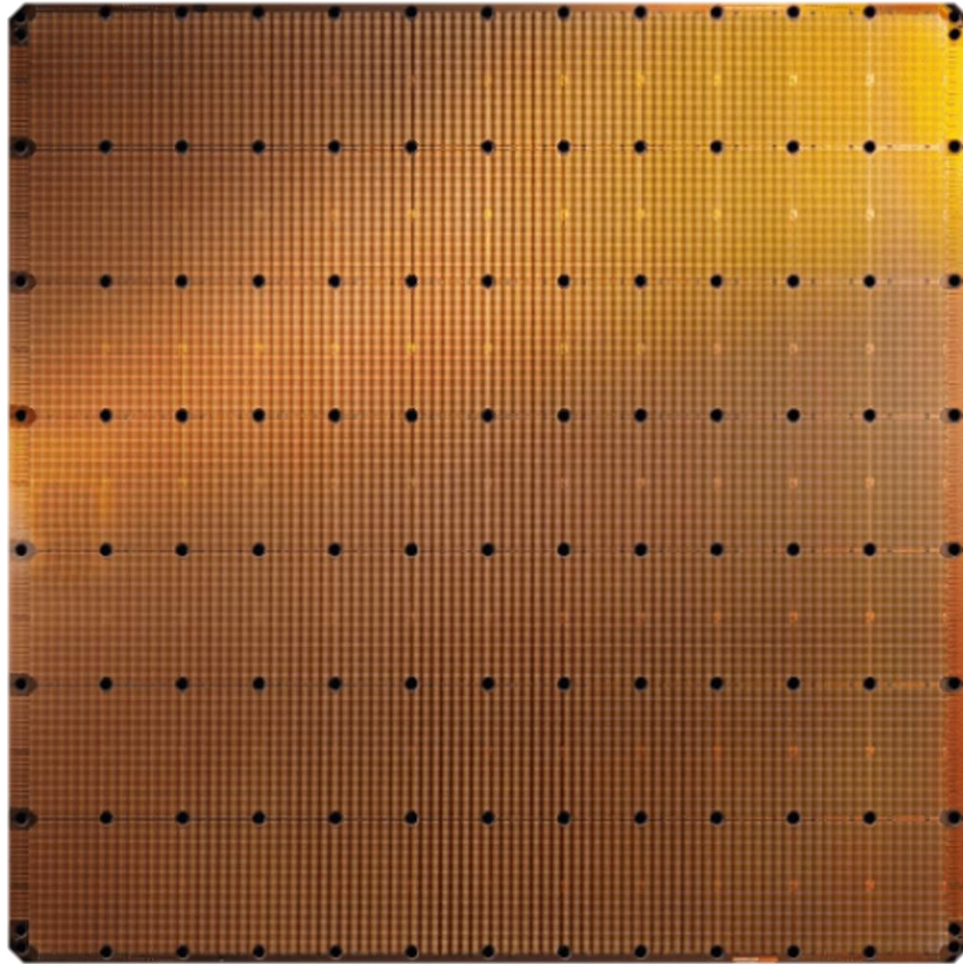

Cerebras WSE-2  
Površina (*area*): 46225 mm<sup>2</sup> (21,5 x 21,5 cm)  
2,6 bilijona tranzistorjev ( $2,6 * 10^{12}$ )



NVIDIA GPE A100  
826 mm<sup>2</sup>  
54,2 milijarde tranzistorjev ( $54,2 * 10^9$ )